

**ORISSA CONSTRUCTION CORPORATION LTD.  
(A GOVT. OF ORISSA UNDERTAKING)  
CENTRAL WORKSHOP, RASULGARH,  
BHUBANESWAR-751010 (ORISSA)**

\* \* \* \* \*

**TENDER DOCUMENT FOR  
“SUPPLY OF BRONZE BUSH FOR PIN JOINTS FOR  
SPILLWAY GATES OF ANANDAPUR BARRAGE PROJECT”.**

The tender document comprises of the following:

1)	Tender call notice No. OCC/CWS/PROC/ABP-08/ 13/11-12 dated 10.10.2011	01 (One) sheet
2)	Terms and conditions	04 (Four) sheets
3)	Drawing	01 (One) sheet
4)	Price schedule	01 (One) sheet
-----		
	Total:	07 (Seven) sheets
-----		

Signature of the tenderer or his/their  
power of attorney holder  
with designation & seal.

Senior Manager (Mech.)-I  
OCC Ltd, Central Workshop,  
Rasulgarh, Bhubaneswar-751010

**ORISSA CONSTRUCTION CORPORATION LIMITED  
(A GOVT. OF ORISSA UNDERTAKING)  
CENTRAL WORKSHOP:RASULGARH,  
BHUBANESWAR-751010 (ORISSA)**

**TENDER CALL NOTICE NO. OCC/CWS/PROC/ABP-08/ 13 /11-12 DTD.10.10.2011**

Sealed tenders in conformity with the terms, conditions, drawing and technical specifications in tender documents are invited from reputed manufacturers/suppliers/ organisations for **"SUPPLY OF BRONZE BUSH FOR PIN JOINTS FOR SPILLWAY GATES OF ANANDAPUR BARRAGE PROJECT"** as per details below:

Cost of tender document (Non-refundable)	Sale of tender document		Earnest money deposit (EMD) required	Receipt of tender	Opening of tender
<b>Rs.2080/-</b> by hand & <b>Rs.2180/-</b> by Regd. post/ courier (inclusive of VAT @ 4% on <b>Rs.2000/-</b> )	From <b>12.10.2011</b>	To <b>27.10.2011</b> up to <b>2.00PM</b>	1(One)% of the total quoted value	Up to 3.00 PM on <b>27.10.2011</b>	At 4.00 PM on <b>27.10.2011</b>

The tender document can be purchased by the interested reputed manufacturers/ suppliers/ organisations by hand from the office of the undersigned on deposit of cost of tender document i.e. **Rs.2000/-** plus VAT @ 4% amounting to **Rs.2080/-** in cash or in shape of A/c. payee demand draft drawn in favour of "Orissa Construction Corporation Limited- Project Account" on any Nationalised Bank/ Scheduled Bank payable at Bhubaneswar (Non-refundable) and production of attested copies of the following documents and verification thereof by the undersigned. The tender document can also be obtained by the interested reputed manufacturers/ suppliers/ organisations by registered post, speed post/courier on sending the cost of tender document i.e. **Rs.2000/-** plus VAT @ 4% plus postage charges of **Rs.100/-** amounting to **Rs.2180 /-** in shape of A/c. payee demand draft drawn as stated above and attested copies of the following documents and verification thereof by the undersigned. The undersigned will not be responsible for any kind of delay by the postal/courier authorities.

- 1) Valid Central Sales Tax/VAT clearance certificate
- 2) PAN Card
- 3) Credentials in support of supply of similar items of similar magnitude and satisfactory performance thereof.
- 4) PAN based Central Excise registration No., if a manufacturer
- 5) Authorised distributorship/stockist/dealership certificate, if not a manufacturer

The tender document can also be downloaded from our Website [www.orissaconstruction.com](http://www.orissaconstruction.com) to submit the tender. However, the cost of tender document i.e. **Rs.2000/-** plus VAT @ 4% amounting to **Rs.2080/-** in shape of A/c payee demand draft as stated above in favour of "Orissa Construction Corporation Limited- Project Account" on any Nationalised Bank/ Scheduled Bank payable at Bhubaneswar (Non-refundable) along with attested photo copies of all above documents should be submitted while submitting the tender in Envelope-I. Otherwise, the tender will be cancelled. OCCL will not be responsible for missing of any page while downloading.

The tenders will be opened in the presence of the tenderers or their authorised representatives. Tender through Fax/Telex/telegram/e-mail will not be accepted

The undersigned reserves the right to accept or reject any or all quotations without assigning any reason thereof.

Signature of the tenderer or his/their  
Power of attorney holder  
with designation & seal.

Senior Manager (Mech.)-I  
OCC Ltd, Central Workshop,  
Rasulgarh, Bhubaneswar-751010

**ORISSA CONSTRUCTION CORPORATION LTD.  
(A GOVT. OF ORISSA UNDERTAKING)  
CENTRAL WORKSHOP, RASULGARH,  
BHUBANESWAR-751010 (ORISSA)**

\* \* \* \* \*

**TERMS AND CONDITIONS OF TENDER FOR  
“SUPPLY OF BRONZE BUSH FOR PIN JOINTS FOR  
SPILLWAY GATES OF ANANDAPUR BARRAGE PROJECT”.**

1. Reputed manufacturers/ suppliers/ organisations having supplied similar item of similar magnitude earlier and satisfactorily accepted by the clients will be eligible to participate in the tender. The copies of purchase orders, credentials, certificates etc. in support of similar supply and satisfactory performance thereof will be furnished along with the tender.
2. The tenderer should submit Earnest Money Deposit (EMD) @ 1(One)% of the total quoted value along with the tender in shape of account payee demand draft drawn in favour of “Orissa Construction Corporation Ltd -Project Account” on any Nationalised Bank/ Scheduled bank payable at Bhubaneswar. The tenders received without EMD will be out rightly rejected. EMD of the unsuccessful tenderers will be released only after finalization of the tender.
3. Tender should be submitted in two bid system in two separate sealed covers and both will be submitted in a single sealed outer cover subscribing in bold letters as **“TENDER FOR SUPPLY OF BRONZE BUSH FOR PIN JOINTS FOR SPILLWAY GATES OF ANANDAPUR BARRAGE PROJECT”** and also date of opening of tender. The name and address of the tenderer should not be written on outer cover. Only the name and address of the purchaser should be written on the outer cover.
4. i) The first envelope super scribing in bold letters as **“TECHNICAL BID”** should contain the following:
  - a. EMD of 1(One)% of quoted value as per clause- 2 above.
  - b. Attested copy of valid Central Sales Tax/ VAT clearance certificates. The tenderer will mention his CST Regn. No./ TIN No./SRIN No. in his tender clearly without which the tender will not be taken into consideration..
  - c. Attested copy of PAN Card.
  - d. Attested copies of purchase orders, credentials, certificates etc. in support of supply of similar item and magnitude and satisfactory performance thereof.
  - e. Complete tender document in original including terms and conditions but without detailed specifications and price schedule duly signed on each page by the tenderer or his/their power of attorney holder. In case of power of attorney holder, an attested copy of power of attorney should be furnished.
- ii) Second envelope subscribing in bold letters **“SPECIFICATION AND PRICE SCHEDULE”** should contain detailed specifications and price schedule in original only duly filled in without leaving any column and line blank and signed on each page by the tenderer or his/their power of attorney holder.

Signature of the tenderer or his/their  
Power of attorney holder  
with designation & seal.

Senior Manager (Mech.)-I  
OCC Ltd, Central Workshop,  
Rasulgarh, Bhubaneswar-751010

5. The tender document can be purchased by the interested reputed manufacturers/ suppliers/ organisations by hand from the office of the undersigned from **12.10.2011** to **27.10.2011** (up to 2.00 PM) during office hours on deposit of cost of tender document i.e. Rs.2000/- plus VAT @ 4% amounting to **Rs.2080/-** in cash or in shape of A/c. payee demand draft drawn in favour of "Orissa Construction Corporation Limited- Project Account "on any Nationalized Bank/Scheduled Bank payable at Bhubaneswar (non-refundable) and production of attested copies of the following documents and verification thereof by the undersigned. The tender document can also be obtained by the interested reputed manufacturers suppliers/ organisations by registered post/speed post/courier on sending the cost of tender document i.e. Rs.2000/- plus VAT @ 4% and postage charges of **Rs.100/-** amounting to **Rs.2180/-** in shape of A/c. payee demand draft drawn in favour of "Orissa Construction Corporation Limited - Project Account" on any Nationalized Bank/Scheduled Bank payable at Bhubaneswar (non-refundable) and sending attested copies of the following documents and verification thereof by the undersigned.
  - a. Valid Central Sales Tax/VAT Clearance Certificate.
  - b. PAN Card
  - c. Credentials in support of supply of similar items of similar magnitude and satisfactory performance thereof.
  - d. Central Excise registration No., if a manufacturer
6. The tender document can also be downloaded from our Website [www.orissaconstruction.com](http://www.orissaconstruction.com) to submit the tender. However, the cost of tender document i.e. Rs.2000/- plus VAT @ 4% amounting to Rs.2080/- in shape of A/c. payee demand draft as stated above in favour of "Orissa Construction Corporation Limited - Project Account" on any Nationalized Bank/ Scheduled Bank payable at Bhubaneswar (non-refundable) along with attested photo copies of all above documents should be submitted, while submitting tender in Envelope-I. Otherwise, the tender will be cancelled. OCCL will not be responsible for missing of any page while downloading.
7. The tenders will be received up to 3.00 PM on **27.10.2011** and will be opened in the office of the undersigned on the same day at 4.00 PM in presence of the tenderers or their authorized representatives, if they so desire.
8. The undersigned will not be responsible for any kind of delay in receipt of tenders by the postal/courier authorities.
9. The first envelope will be opened on **27.10.2011** at 4.00 PM first. Then the documents in the first envelope submitted by the tenderers will be scrutinized preliminarily on the spot. The second envelope of the valid eligible tenders after preliminary scrutiny of the documents in the first envelope will be opened on the same day immediately subject to fulfilling the requirements mentioned in the tender schedule.
10. The materials in proof machined condition should be supplied by the successful tenderer/supplier as per drawing and should strictly confirm to relevant standards of bureau of Indian /standards (BIS) as mentioned in tech,. Specifications and price schedule.

Signature of the tenderer or his/their  
Power of attorney holder  
with designation & seal.

Senior Manager (Mech.)-I  
OCC Ltd, Central Workshop,  
Rasulgarh, Bhubaneswar-751010

11. The original test certificate of materials from a Govt./Govt. approved testing laboratory will be provided by the successful tenderer/ supplier along with supply of materials. The manufacturer's test certificate will have to be also furnished by the successful tenderer/ supplier. The purchaser is having the option to test the materials in any laboratory at the cost of the supplier and if the materials are not found in accordance with the specifications and grade in relevant Indian Standards, the materials will be rejected.
12. The materials will be guaranteed by the supplier against any defect for a period of 18 months from the date of supply or 12 months from the date of use, whichever is earlier. Guarantee certificate in this regard will accompany with supply of materials. If any defect is found in the materials within the guarantee period, the same will have to be replaced free of cost by the supplier.
13. The successful tenderer shall have to furnish a performance bank guarantee for 10% value of materials within 30 days from the date of issue of Purchase Order. The Bank Guarantee shall be released after completion of the guarantee period.
14. Pre-delivery inspection (P.D.I) before despatch of the materials will be made at the manufacturer's works by the authorized representative of the purchaser for which the manufacturer should intimate in writing for P.D.I. 10 days in advance regarding readiness for P.D.I.
15. The rate of each item should be quoted by the tenderer on piece basis only. If the rate is quoted per unit weight or otherwise, the tender will be out rightly rejected.
16. The tenderer will quote their rates F.O.R. OCCL Store, Central Workshop, Rasulgarh, Bhubaneswar-10 (Orissa) indicating separately the basic price, packing, forwarding, transportation, transit insurance, handling charges, taxes, duties, levies etc. strictly in the specifications and price schedule format in original. All columns and lines of the specification and price schedule should be filled in properly without leaving any thing blank. The details and rates of duties, taxes etc. should be indicated clearly in the specification and price schedule.
17. 'C' form for availing concessional CST shall not be issued by OCCL to the successful tenderer from outside the state of Orissa for which the tenderer should quote full taxes on their offer.
18. Waybills shall not be issued for despatch of materials. The successful tenderer should despatch the materials to destination of OCCL by his own arrangements without any further liability / responsibility on OCCL.
19. In case the excise duty is payable by the successful tenderer, the excise invoice will have to be furnished with the bill to avail CENVAT/MODVAT facility by the purchaser.

Signature of the tenderer or his/their  
Power of attorney holder  
with designation & seal.

Senior Manager (Mech.)-I  
OCC Ltd, Central Workshop,  
Rasulgarh, Bhubaneswar-751010

20. The rates and amounts should be quoted both in figures and words in the price schedule. Any correction or overwriting in the specification and price schedule should be duly certified by the tenderer or his power of attorney holder. In case of any mismatch in figures and words, the rates in words will be considered. In case of any mismatch in rates and amount, the rate will be considered.
21. 90% payment will be made within 30 days of receipt, verification and acceptance of the complete materials along with bill, test certificate, guarantee certificate and other documents. Balance 10% will be released after 18 months of supply or 12 months from the date of commissioning whichever is earlier. However if a performance bank guarantee is received for 10% of the total basic cost, the same will be released within 60 days from the date of receipt of materials.
22. The purchaser reserves the right to forfeit and encash the performance bank guarantee in full in case any bronze casting is found defective and not replaced by the tenderer/supplier within a suitable time fixed by the corporation. Any repair to the bronze casting shall be made only after approval of the purchaser. In this connection, the decision of the purchaser is final and binding on the tenderer/supplier.
23. Price escalation will not be allowed under any circumstances. The quoted rates will remain firm till execution of the work order.
24. 'The validity of the offer should be for a period of 120 (One hundred twenty) days from the date of opening of the tender.
25. The complete ordered quantity shall be supplied by the successful tenderer within 60(Sixty) days from the date of issue of purchase order failing which penalty @ 0.5% (Half percent) of the total order value per week of delay or part thereof subject to a maximum of 5% (Five percent) of the total order value shall be imposed. There after, the order may be cancelled with the discretion of the purchaser. In case of cancellation of the order, the EMD will be forfeited.
26. Conditional offers with deviations will not be accepted. Those, who do not agree to the terms and conditions regarding payments, delivery and others, need not quote.
27. The authority reserves the right to accept/reject any or all tenders without assigning any reason thereof. The required quantity of materials can be splitted among the two or more tenderers. In this connection, the decision of purchaser is final and binding on the tenderer.
28. Tender through fax/telex/telegram/e-mail will not be accepted.
29. Any dispute arising out of this tender or order thereof is to be settled in proper court under the jurisdiction of Orissa High Court at Cuttack or courts under the jurisdiction of Orissa High Court at Bhubaneswar only.

Signature of the tenderer or his/their  
Power of attorney holder  
with designation & seal.

Senior Manager (Mech.)-I  
OCC Ltd, Central Workshop,  
Rasulgarh, Bhubaneswar-751010.

**ORISSA CONSTRUCTION CORPORATION LIMITED  
(A GOVT. OF ORISSA UNDERTAKING)  
CENTRAL WORKSHOP:RASULGARH,  
BHUBANESWAR-751010 (ORISSA)**

**DETAILED TECHNICAL SPECIFICATION AND PRICE SCHEDULE FOR  
" SUPPLY OF BRONZE BUSH FOR PIN JOINTS FOR SPILLWAY GATES OF ANANDAPUR BARRAGE PROJECT ".**

Sl. No	Description of item	Quantity Required in No.	Rate per each in Rs.							Total amount in Rs. for full materials	
			Weight of each in proof machined condition	Basic Price per each	P & F Trans. Transit insurance & Handling charges	Duties	Taxes	Total in figures	Total in words	In figure	In words
1	<b>BRONZE BUSH (12-10) :</b> Material: Alluminium Bronze, Grade: AB-2 of IS:305 In proof machined condition keeping suitable machining allowances as per drawing enclosed	50 (Fifty)									
2	<b>BRONZE BUSH (12-19) :</b> Material: Alluminium Bronze, Grade: AB-2 of IS:305 In proof machined condition keeping suitable machining allowances as per drawing enclosed	50 (Fifty)									
3	<b>BRONZE BUSH (12-24) :</b> Material: Alluminium Bronze, Grade: AB-2 of IS:305 In proof machined condition keeping suitable machining allowances as per drawing enclosed	50 (Fifty)									

Signature of the tenderer or his/their  
Power of attorney holder  
with designation & seal.

Senior Manager (Mech.)-I  
OCC Ltd, Central Workshop,  
Rasulgarh, Bhubaneswar-751010.

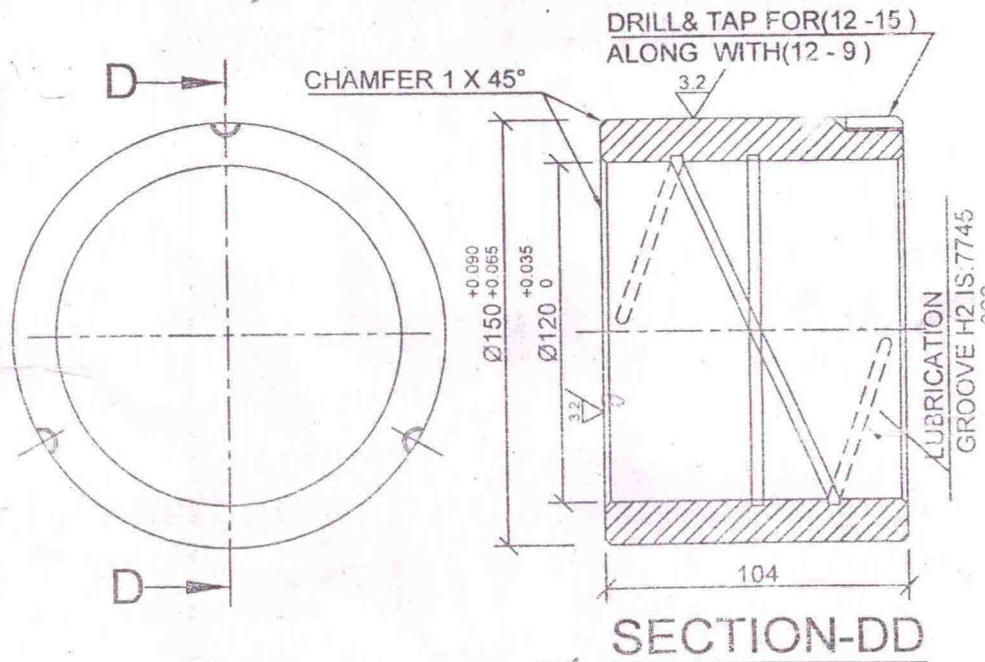

**BRONZE BUSH** (12-10)

MATERIAL- ALUMINIUM BRONZE Gr.AB2 OF IS:305

QUANTITY - 50 (Fifty) Nos.

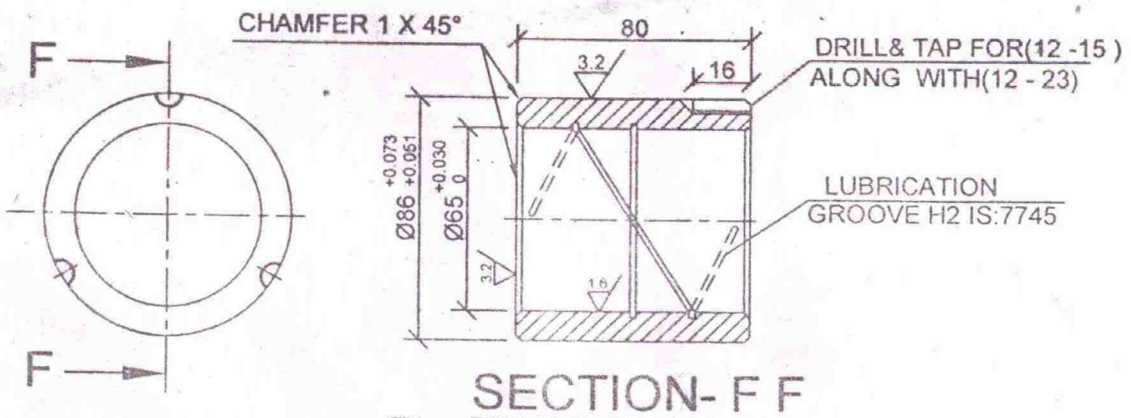

**BRONZE BUSH** (12-24)

MATERIAL- ALUMINIUM BRONZE Gr.AB2 OF IS:305

QUANTITY - 50 (Fifty) Nos.

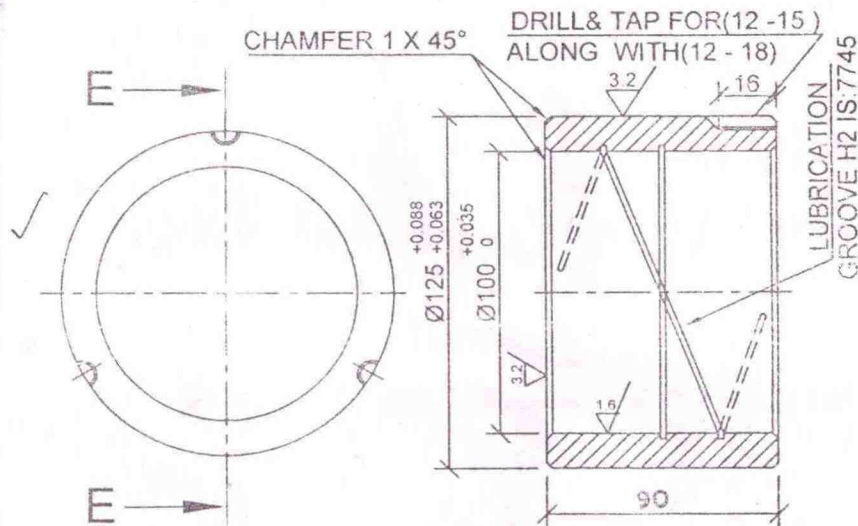

**BRONZE BUSH** (12-19)

MATERIAL- ALUMINIUM BRONZE Gr.AB2 OF IS:305

QUANTITY - 50 (Fifty) Nos.